

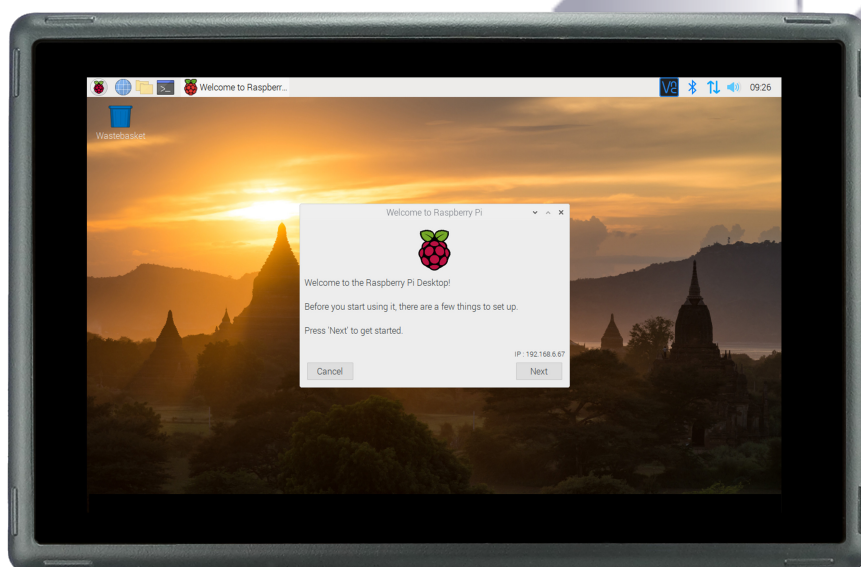

Industrial PC

PPC-CM4-070-D



PN: CS10600RA4070P-D

Content can change at anytime, check our website for latest information of this product.

www.chipsee.com

Contents

PPC-CM4-070-D	3
1. Product Overview	7
2. Ordering Options	8
2.1. Pi [®] CM4 Module	8
2.2. Operating System	8
2.3. Optional Features	9
3. 7 inch CM4 Products Comparision	10
4. Specifications	11
5. Power Input	13
6. Touch Screen	15
7. Connectivity	16
7.1. RS232/RS485/CAN	16
7.2. GPIO Port	18
7.3. USB Connectors	21
7.4. LAN	23
7.5. WiFi & BT Module	24
7.6. 3G/4G/LTE Module	25
7.7. Zigbee Module	27
7.8. Camera Connector	29
8. TF Card Slot	31
9. Audio Connectors	32
10. PROG Button	33
11. Mounting Procedure	34
12. Mechanical Specifications	35
12.1. CS10600RA4070P-D	35
13. 3D Model	36
14. Disclaimer	37
15. Technical Support	37

PPC-CM4-070-D

Front View

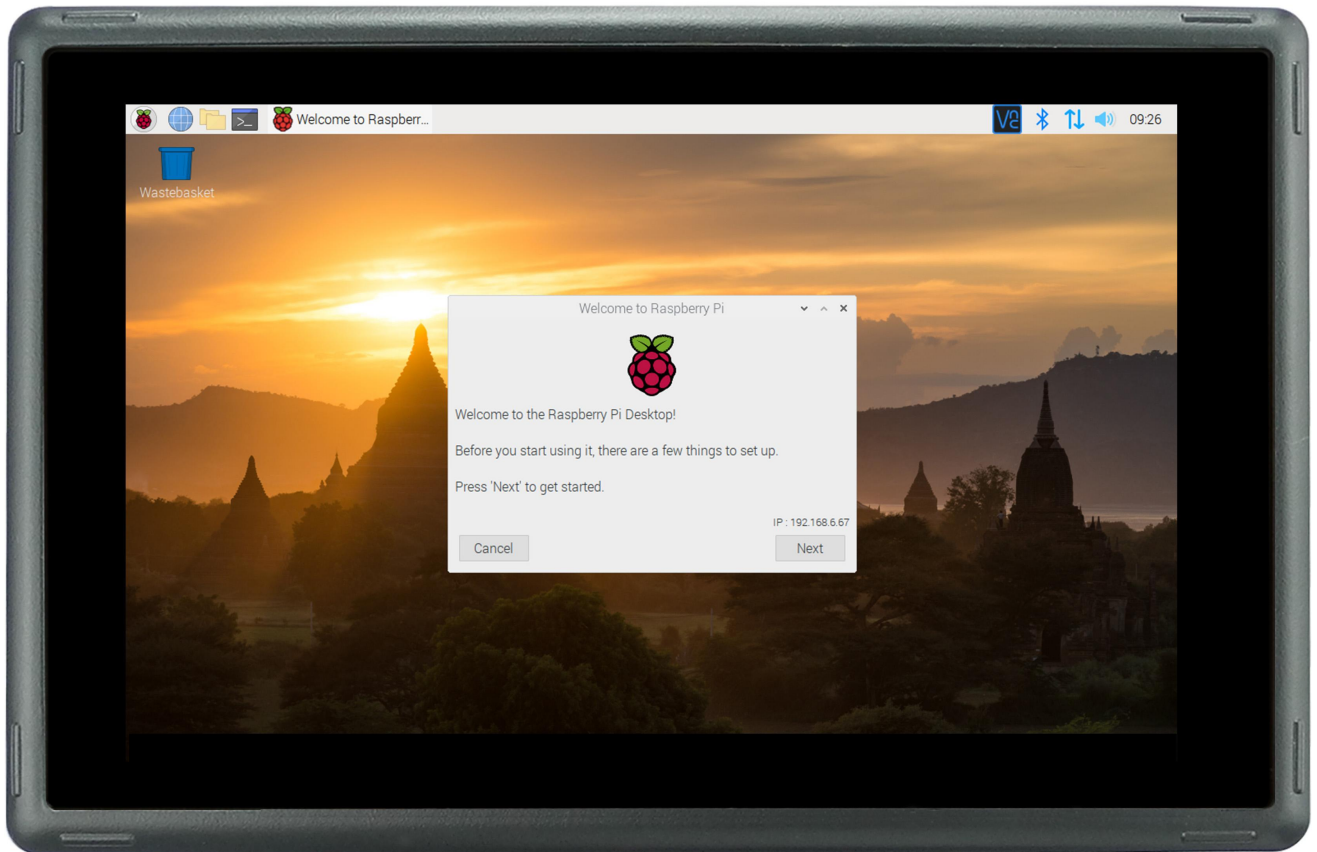

Rear View



Side View 1

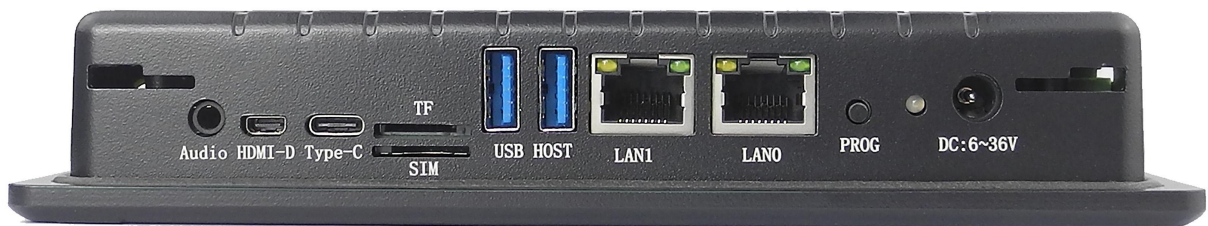

Side View 2

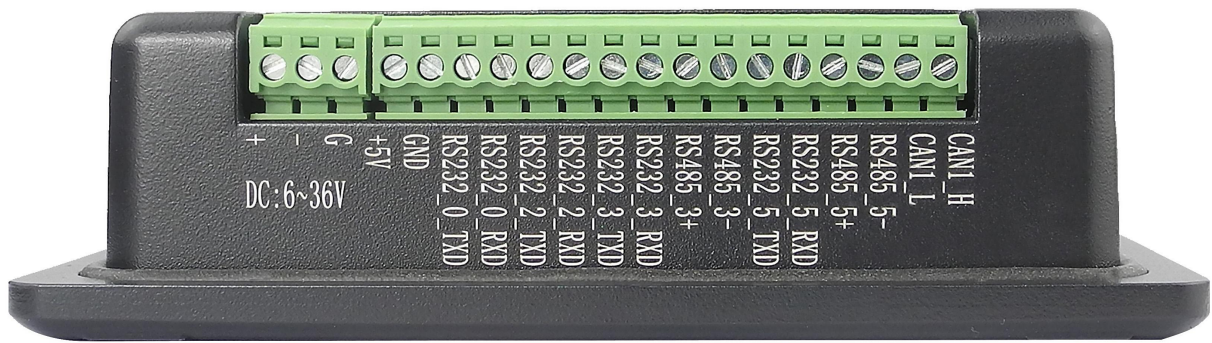

Product Overview

The Cortex[®]-A72 Raspberry Pi[®] series PPC-CM4-070-D (PN: CS10600RA4070P-D) is a high-quality industrial Pi PC. It features a 7" five-point capacitive touch screen with a resolution of 1024 x 600 pixels and brightness of 500 cd/m².

Key Applications

- Human Machine Interface HMI
- Process Control
- Process Monitoring
- HMI
- IIoT node
- Environmental Monitoring
- PLC
- Automotive applications
- ATM...

It is available both as an embedded solution and as a device housed in a casing with bezels, thus facilitating different installation options:

- Installation on an industrial cabinet
- Integration with the existing equipment

The PPC-CM4-070-D industrial Pi PC is based around the powerful Raspberry Pi[®] Compute Module 4, powered by the Quad Cortex[®]-A72 processor with a processor speed of 1.5GHz.

Ordering Options

Chipsee products can be customized during the ordering process. The product will be shipped with the pre-installed factory defaults if no extra requirements are specified. The table in the [Specifications](#) section provides information about the default options bundled with the product.

Note

You can order [PPC-CM4-070-D](#) from the official [Chipsee Store](#) or from your nearest distributor.

Pi[®] CM4 Module

The Pi[®] Compute Module 4 appears in different versions depending on the size of the DDR4 and eMMC.

The PPC-CM4-070-D industrial Pi PC does not include the CM4 Raspberry Pi[®] module by default. If you would like to purchase it with a CM4, you can select it at the Chipsee store during the ordering process.

Operating System

This product comes with a pre-installed Raspberry Pi OS. Chipsee software engineers have created all the drivers, so every hardware feature is readily available for any standard development tool.

If your project requires a different OS, please [Contact us](#), and we'll make a [customized version](#) that suits your needs.

Optional Features

The PPC-CM4-070-D industrial Pi PC does not include the 3G/4G/LTE modules by default. These modules are optional and can be selected at the Chipsee store during the ordering process.

Warning

Installation, repair, and maintenance tasks should be performed by trained personnel only. Chipsee does not bear any responsibility for damage caused by inadequate handling of the product.

7 inch CM4 Products Comparison

Chipsee provides two 7 inch Industrial Pi PCs, EPC/PPC-CM4-070 and PPC-CM4-070-D, here is the comparison:

Product	EPC/PPC-CM4-070	PPC-CM4-070-D
LAN	1 x LAN	2 x LAN
USB-A	2 x USB 2.0	2 x USB 3.0
GPIO	8 x Optical Isolated GPIO	6 x Raspberry Pi CPU GPIO (Compatible with Pi GPIO Software Libraries) or 8 x Optical Isolated GPIO
Connectors	Distributed on each side	Mostly on the bottom side
Dimension	206 x 135 x 30mm	188.05 x 123.11 x 33.20mm, new case, small and compact

Table 289 Comparison Between the 7 inch CM4 Products

Specifications

The PPC-CM4-070-D industrial Pi PC offers a broad range of performance and connectivity options for scalable integration, providing expandability according to future needs. Some of the key features are listed in the table below.

PPC-CM4-070-D	
CPU	Raspberry Pi [®] CM4, CM4 Lite; Quad Cortex-A72 at 1.5GHz
Storage	Support for 1 x TF Card ³
RAM	2/4/8 GB, Based on CM4
eMMC	16/32 GB, Based on CM4
Display	7" IPS LCD, 1024 x 600 resolution px, brightness 500 cd/m ²
Touch	5-point capacitive touch with 1mm Armored Glass
USB	2 x USB 3.0 Host, 1 x USB Type-C OTG
LAN	2 x Giga LAN (optional PoE support for LAN0)
Audio	3.5mm Audio Out Connector, 2W Speaker Internal
Buzzer	Onboard Buzzer, driven by GPIO
RTC	High accuracy RTC with farad capacitor, can work 1 week after power off (default). High accuracy RTC with lithium coin battery, can work 3 years after power off (<i>optional</i>).
RS232	Default to 2 x RS232, up to 4 x RS232
RS485	Default to 2 x RS485 ¹ , these 2 x RS485 can be configured as 2 x RS232
CAN	1 x CAN-BUS
GPIO	Option 1: 4 x input, 4 x output from expander IC (optical isolated, DEFAULT). Option 2: 6 x CM4 CPU GPIO (conflict with option 1).
I2C	Not Supported
WiFi/BT	Supported but depending on the CM4 selected ²
ZIGBEE	Onboard Zigbee module, not mounted by default
HDMI	Yes
SATA II	Not Supported
3G/4G/LTE	Supported, not mounted by default
Camera	Yes, not mounted by default. Available on the board in the embedded PC. Requires a customized case to be exposed in an enclosed PC.
Power Input	From 6V to 36V
Current	700mA (max); 530mA (maximum backlight, idle); 400mA (minimum backlight, idle) at 12V

PPC-CM4-070-D	
Power Consumption	8.4W (max); 6.36W (maximum backlight, idle); 4.8W (minimum backlight, idle)
Working Temperature	From 0°C to +60°C
OS	Raspberry Pi OS
Dimensions	CS10600RA4070P-D: 188.05 x 123.11 x 33.20mm
Weight	CS10600RA4070P-D: 700g
Mounting Method	CS10600RA4070P-D: Panel, VESA

Table 290 Key Features

- 1 The RS485 circuit controls the Input and Output direction automatically, there's no need to control it from within the software.
- 2 The default product without the CM4 does not include a Wi-Fi/BT module. You can include a CM4 that has the Wi-Fi/BT module at the Chipsee store during the ordering process.
- 3 Chipsee designed one TF card slot for CM4 Lite version which has no eMMC to boot OS.

Power Input

The PPC-CM4-070-D industrial Pi PC can be powered by a wide range of input voltages: From 6V to 36V DC. There are two types of power input connectors. One is a **3 Pin, 3.81mm screw terminal** connector, and the other is a **2.1mm DC input head**. As shown in the figure below.

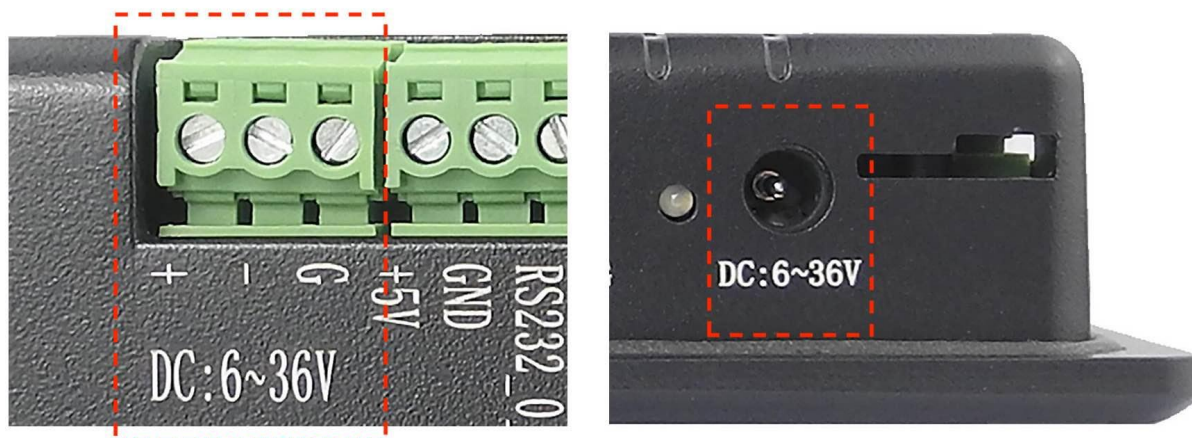

Power Input

Note that the “+” sign represents the positive power input, and it is printed both at the casing and as a silk-screen on the board of the embedded version. The “-” terminal is shorted to the ground.

Power Input Definition		
Pin Number	Definition	Description
Pin 1	Positive Input	DC Power Positive Terminal
Pin 2	Negative Input	DC Power Negative Terminal
Pin 3	Ground	Power System Ground

Table 291 Power Connector

 **Note**

The system ground “G” is connected to power negative “-” on board.

There is another power input port, it is a 2.1mm x 5.5mm x 9.5mm DC jack. For a proper DC power connector, refer to the figure below.

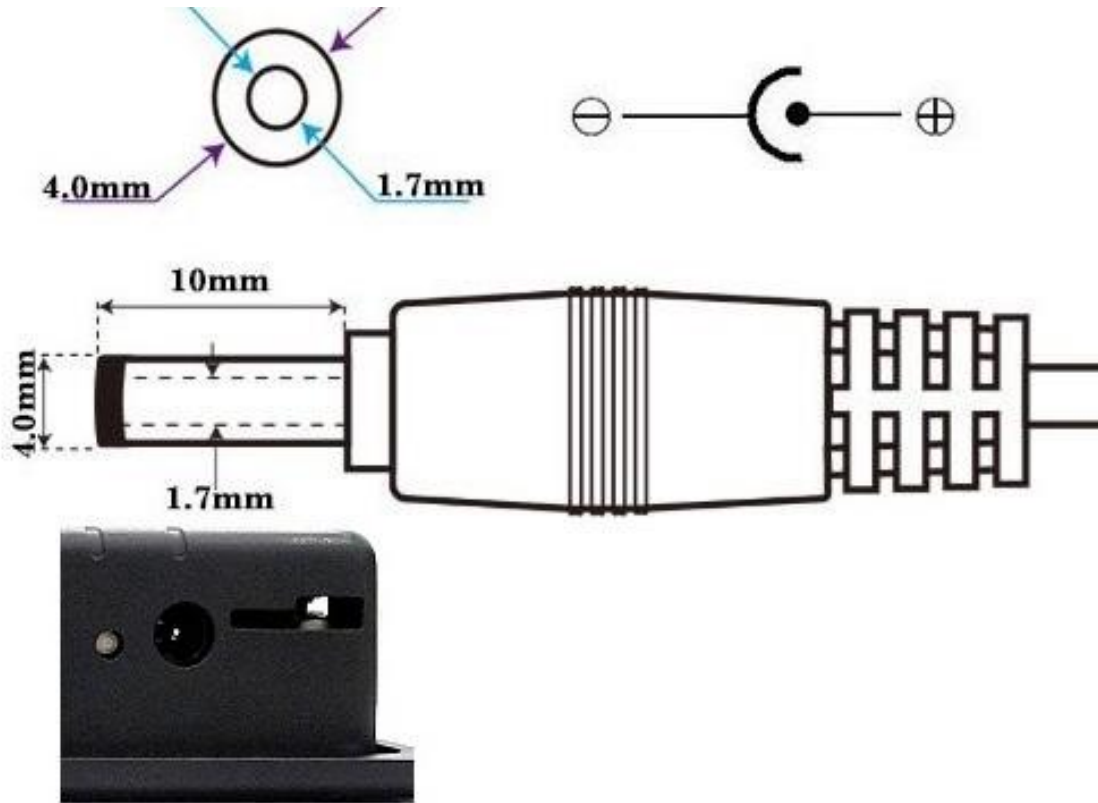

DC Jack

Touch Screen

The PPC-CM4-070-D industrial Pi PC uses a 5-point capacitive touch with 1mm Armored Glass screen. However, the Raspberry Pi OS supports only One-Point touch.

The figure below shows the capacitive touch screen connected to the motherboard via the FPC connector.

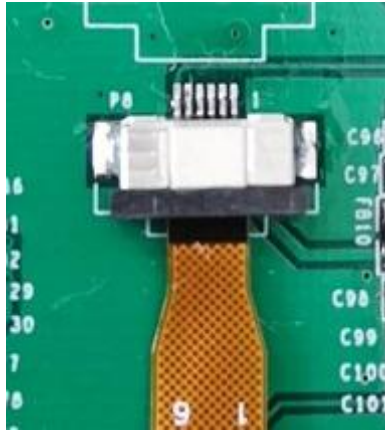

Capacitive Touch Connector

⚠ Attention

A capacitive touch screen is susceptible to power noise and Electromagnetic Radiation (EMR). It may cause LCD ripples or even capacitive touch malfunction. If using a capacitive multi-touch test application, you might notice the touch points float erratically across the display. There are several solutions to this problem:

1. Use a high-quality Power Adapter Unit (PSU) with low EMR. You can also provide power from a battery.
2. Make sure that the PPC-CM4-070-D Power Input connector (pin 3) is properly connected to the Power System Ground to provide sufficient EMI shielding and eliminate the problem entirely.
3. Bad GND problems can also be confirmed by touching pin 3 of the Power Input connector with one hand while operating the capacitive touch screen with the other hand. In this case, the operator's body acts as the Power System Ground.

Connectivity

There are many connectivity options available on the PPC-CM4-070-D industrial Pi PC. It has 2 x USB 3.0 Host, 1 x USB Type-C OTG, 2 x Giga LAN (**optional** PoE support for LAN0) (RJ45) Ethernet connector supporting up to 1 Gbps, and 4 x UART and 1 x CAN terminals (RS232/RS485/CAN).

RS232/RS485/CAN

The serial communication interfaces (RS485, RS232, and CAN) are routed to a 16-pin 3.81mm terminal, as illustrated in the figure below.

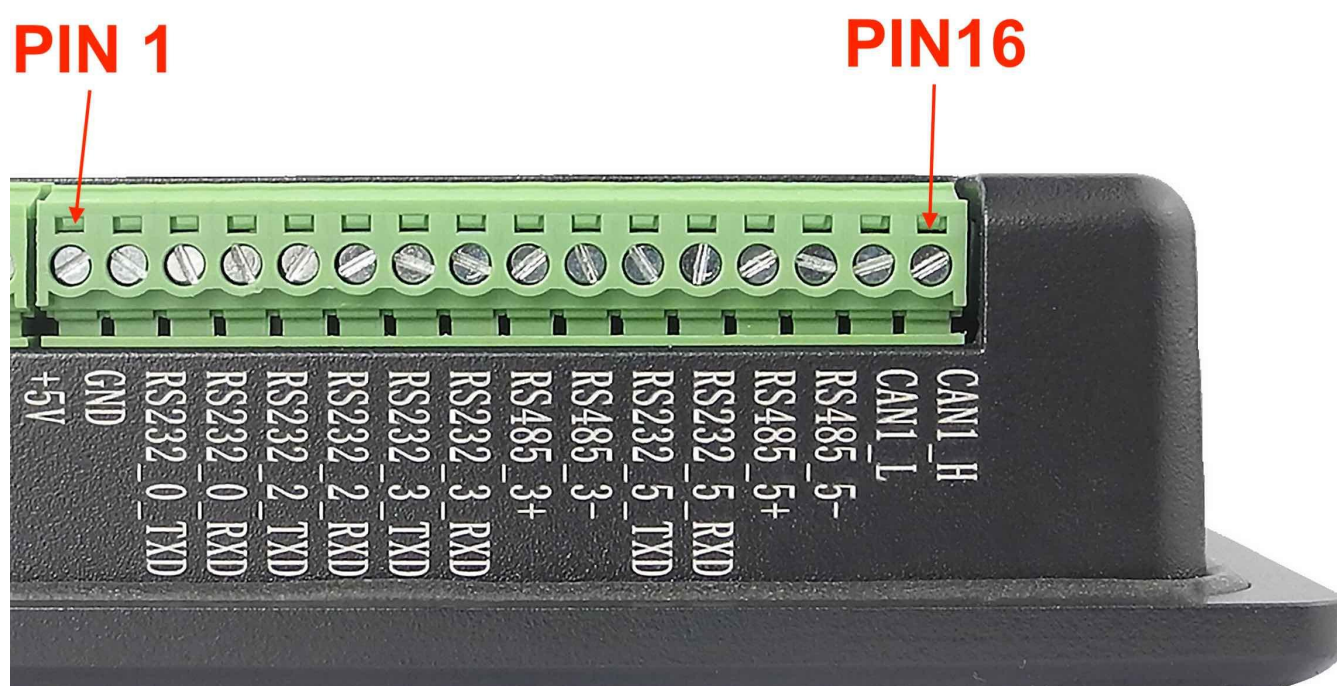

RS232-RS485-CAN on the PPC-CM4-070-D Industrial PC

Attention

1. RS485_3 and RS485_5 can control the input and output direction automatically. There's no need to control it from within the software.
2. The 120Ω match resistor for RS485 is **already** mounted by default.
3. The 120Ω match resistor for CAN is **NOT** mounted by default. Be sure to mount the match resistor when testing CAN.
4. RS485_3 and RS232_3 share UART3 and can't work at the same time; RS485_5 and RS232_5 share UART5 and can't work at the same time. Meaning the product provides 4 x RS232 + 0 x RS485, or 2 x RS232 + 2 x RS485, or 3 x RS232 + 1 x RS485.

The table below offers more detailed description of every pin and its definition:

RS232 / RS485 / CAN Pin Definition:		
Pin Number	Definition	Description
Pin 16	CAN_H	CAN BUS "H" signal
Pin 15	CAN_L	CAN BUS "L" signal
Pin 14	RS485_5-	CPU UART5, RS485 -(B) signal
Pin 13	RS485_5+	CPU UART5, RS485 +(A) signal
Pin 12	RS232_5_RXD	CPU UART5, RS232 RXD signal
Pin 11	RS232_5_TXD	CPU UART5, RS232 TXD signal
Pin 10	RS485_3-	CPU UART3, RS485 -(B) signal
Pin 9	RS485_3+	CPU UART3, RS485 +(A) signal
Pin 8	RS232_3_RXD	CPU UART3, RS232 RXD signal
Pin 7	RS232_3_TXD	CPU UART3, RS232 TXD signal
Pin 6	RS232_2_RXD	CPU UART2, RS232 RXD signal
Pin 5	RS232_2_TXD	CPU UART2, RS232 TXD signal
Pin 4	RS232_0_RXD	CPU UART0, RS232 RXD signal
Pin 3	RS232_0_TXD	CPU UART0, RS232 TXD signal
Pin 2	GND	System Ground
Pin 1	+5V	System +5V Power Output, No more than 1A Current output

Table 292 Connectivity Section

GPIO Port

The PPC-CM4-070-D industrial Pi PC has a 10 Pin 3.81mm **GPIO Connector**, as shown in the figure below. The table below gives details about the definition of every Pin.

Attention

1. In order to use the Isolated Output, you need to add an external Isolated Power to the VDD_ISO and GND_ISO. The power voltage should not exceed 24V.
2. The output current can achieve 500mA for every channel, but it also depends on the isolated power that is connected.
3. In order to use the Isolated Input, you need to add a signal to the ISO_InputX and GND_ISO. A 2.4KΩ resistor, as shown in the figure above. This resistor should work well for the 5-24V input signal. If your input signal is less than 5V, please change this input resistor.

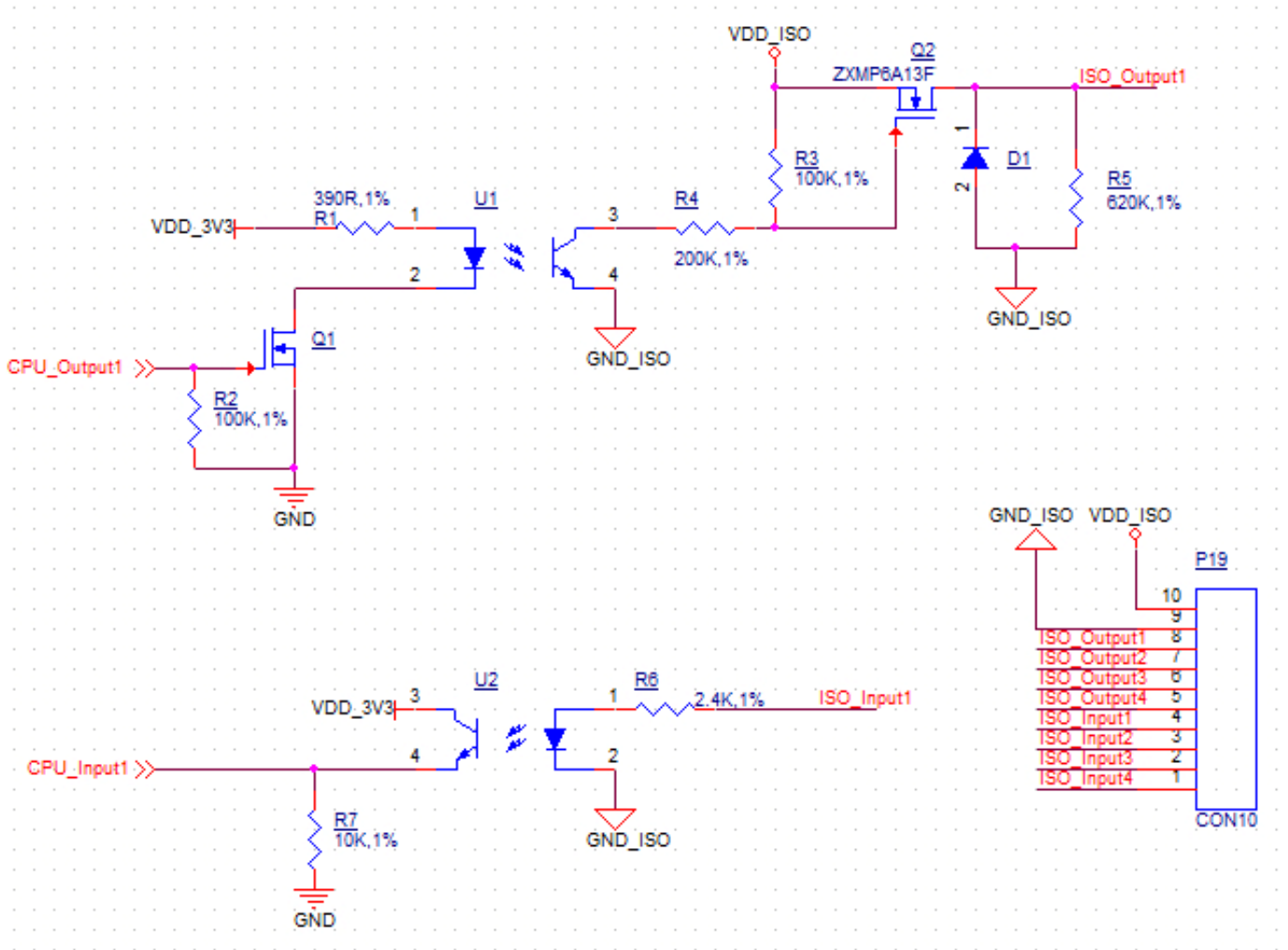

Isolated GPIO reduced schematic

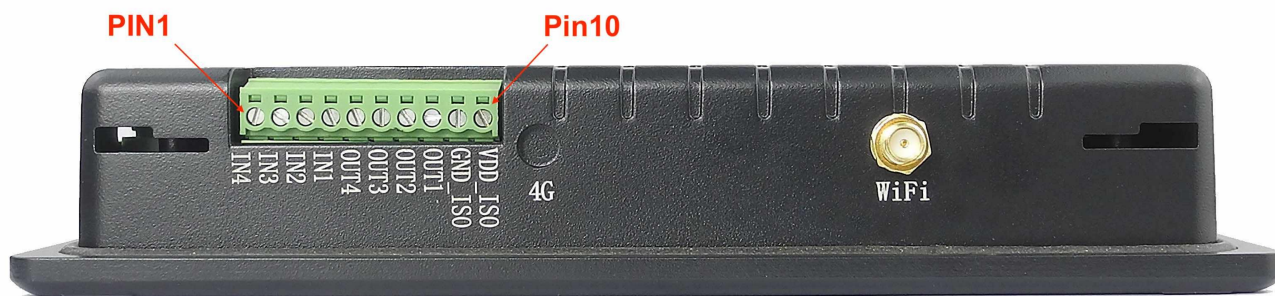

GPIO Connector

GPIO Connector Pin Definition:		
Pin Number	Definition	Description
Pin 10	VDD_ISO	Isolated Power +5V ~ +24V Input
Pin 9	GND_ISO	Isolated Ground
Pin 8	OUT1	Isolated Output 1
Pin 7	OUT2	Isolated Output 2
Pin 6	OUT3	Isolated Output 3
Pin 5	OUT4	Isolated Output 4
Pin 4	IN1	Isolated Input 1
Pin 3	IN2	Isolated Input 2
Pin 2	IN3	Isolated Input 3
Pin 1	IN4	Isolated Input 4

Table 293 GPIO Connector Pin-out

The PPC-CM4-070-D also supports GPIO routed from the Raspberry Pi CM4 CPU directly, if you choose to use the 6 channel **CPU GPIO**, instead of 8 channel **optical isolated GPIO**, you can take advantage of the community software libraries of Pi GPIO. If you choose to use CPU GPIO, you won't be able to use the 8 channel optical isolated GPIO. Below is the pin definition of CPU GPIO:

Warning

Without the optical isolation, CPU might be damaged if dangerous voltages are applied to CPU GPIO. Be careful when using CPU GPIO directly.

CPU GPIO Pin Definition:		
Pin Number	Definition	Description
Pin 10	VDD_ISO	VDD_3V3
Pin 9	GND_ISO	GND
Pin 8	OUT1	GPIO22
Pin 7	OUT2	GPIO23
Pin 6	OUT3	GPIO24
Pin 5	OUT4	GPIO25
Pin 4	IN1	GPIO26
Pin 3	IN2	GPIO27
Pin 2	IN3	NC
Pin 1	IN4	NC

Table 294 CPU GPIO Pin Out

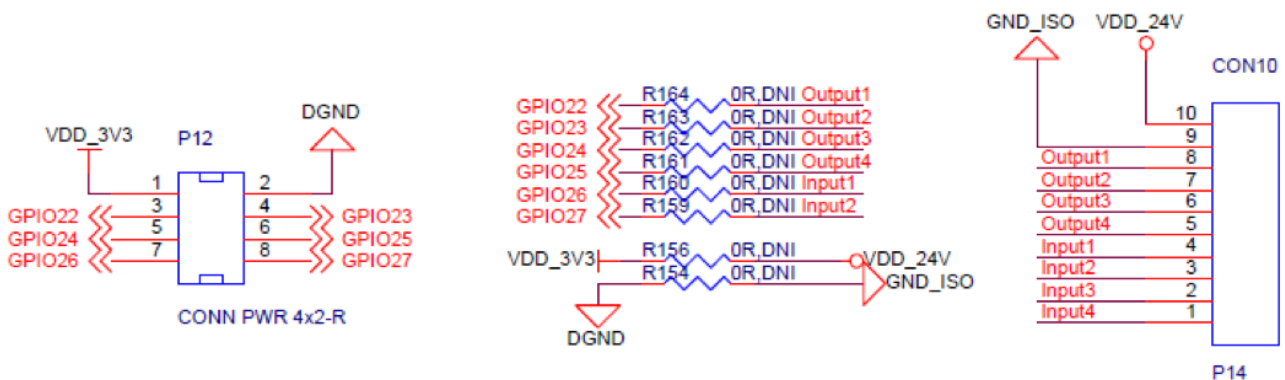

CPU GPIO Reduced Schematic

USB Connectors

There are 2 x USB 3.0 Host, 1 x USB Type-C OTG onboard, as shown in the figure below.

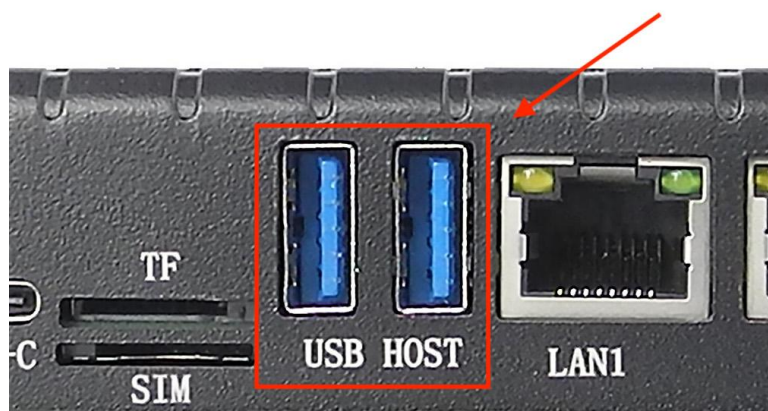

USB HOST Connectors

⚠ Attention

1. These two USB host connectors can drive 500mA for each channel at most.

The product has one USB Type-C OTG connector that works as a slave by default. You can use it to establish a connection with the host PC and for downloading the system to the eMMC of CM4 module.

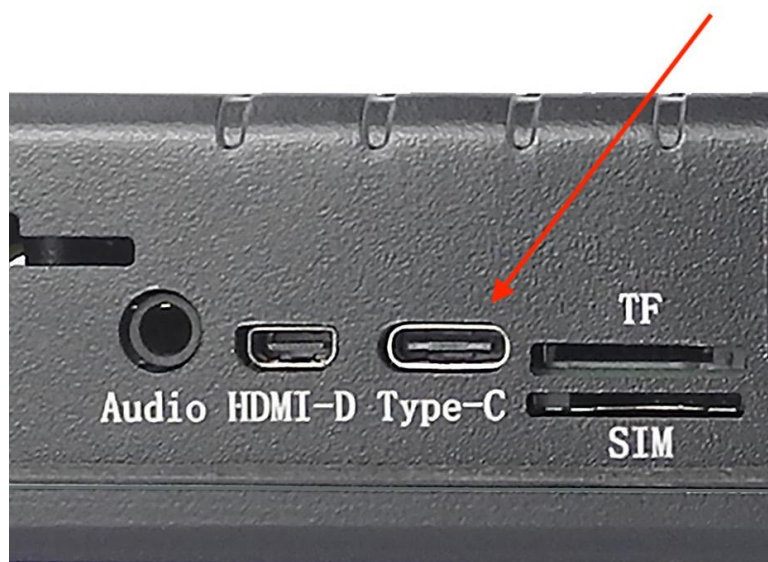

USB Type-C OTG Connector

 **Warning**

1. Be careful not to touch surrounding electronic components accidentally while plugging in USB devices into the embedded Industrial PC version.
2. Remember to unplug the Type-C cable after flashing OS, otherwise the USB hosts won't work.

LAN

The 2 x Giga LAN (**optional** PoE support for LAN0) provides Ethernet connectivity over standardized Ethernet cables as shown in the figure below. The integrated Ethernet interface supports up to 1 Gbps data throughput. These Giga LAN signals come from the CM4 module directly.

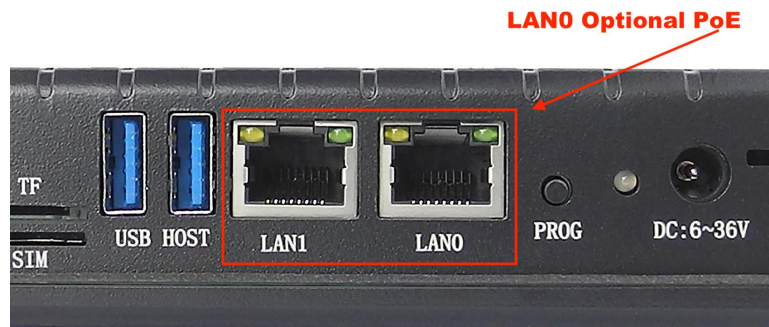

Rj45 LAN Connector

Note

Use CAT5 or better cables to achieve full data throughput over maximum distance defined by the 1000BASE-T standard (100m).

WiFi & BT Module

The default PPC-CM4-070-D without the CM4 does not include a Wi-Fi/BT module. If you include a CM4 that has the Wi-Fi/BT module, the product will have Wi-Fi/BT feature. The enclosed (CS10600RA4070P-D) variant of the product also includes an SMA connector for an external WiFi/BT antenna, as illustrated in the figure below.



WiFi+BT Antenna

Attention

The product does not come shipped with the Wi-Fi/BT module by default.

3G/4G/LTE Module

The PPC-CM4-070-D industrial Pi PC is equipped with a **mini-PCle connector** that can connect to a 3G/4G/LTE module. The customer will also need a SIM Card Holder and a 3G/4G/LTE antenna to ensure 3G/4G/LTE works on the PPC-CM4-070-D. SIM card does **NOT** support hot plug. **Power off** before inserting or removing SIM card.

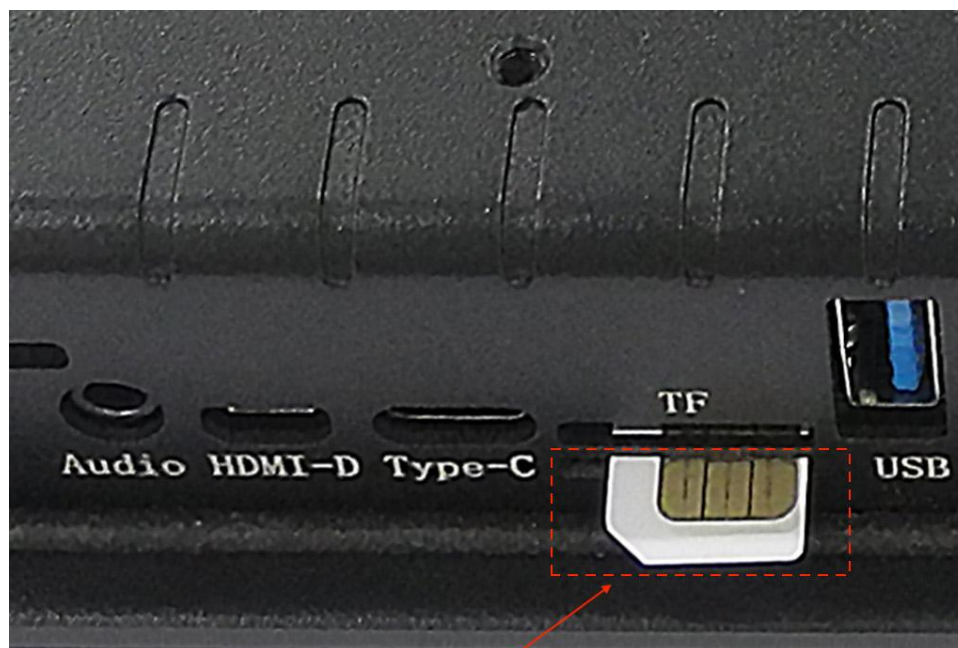

SIM Card Direction

SIM Card Direction



Figure 936: 3G/4G/LTE Module



Figure 937: SIM Card Holder and 3G/4G/LTE Antenna

⚠ Attention

The product does not come shipped with the 3G/4G/LTE module by default. If you need to use 3G/4G/LTE, you can contact us when placing an order, we can install the necessary hardware for you.

Zigbee Module

The PPC-CM4-070-D industrial Pi PC supports an onboard Zigbee module. The Zigbee controller is TI CC2531, and the Raspberry Pi forum supports it.

For CS10600RA4070P-D, there is a connector on the backside of the case that you can use to connect the external Zigbee antenna, as described in the figure below. If you need to use WiFi/BT and Zigbee together, we can customized the case and add another SMA connector for you, usually across the rear to the opposite of the current SMA.

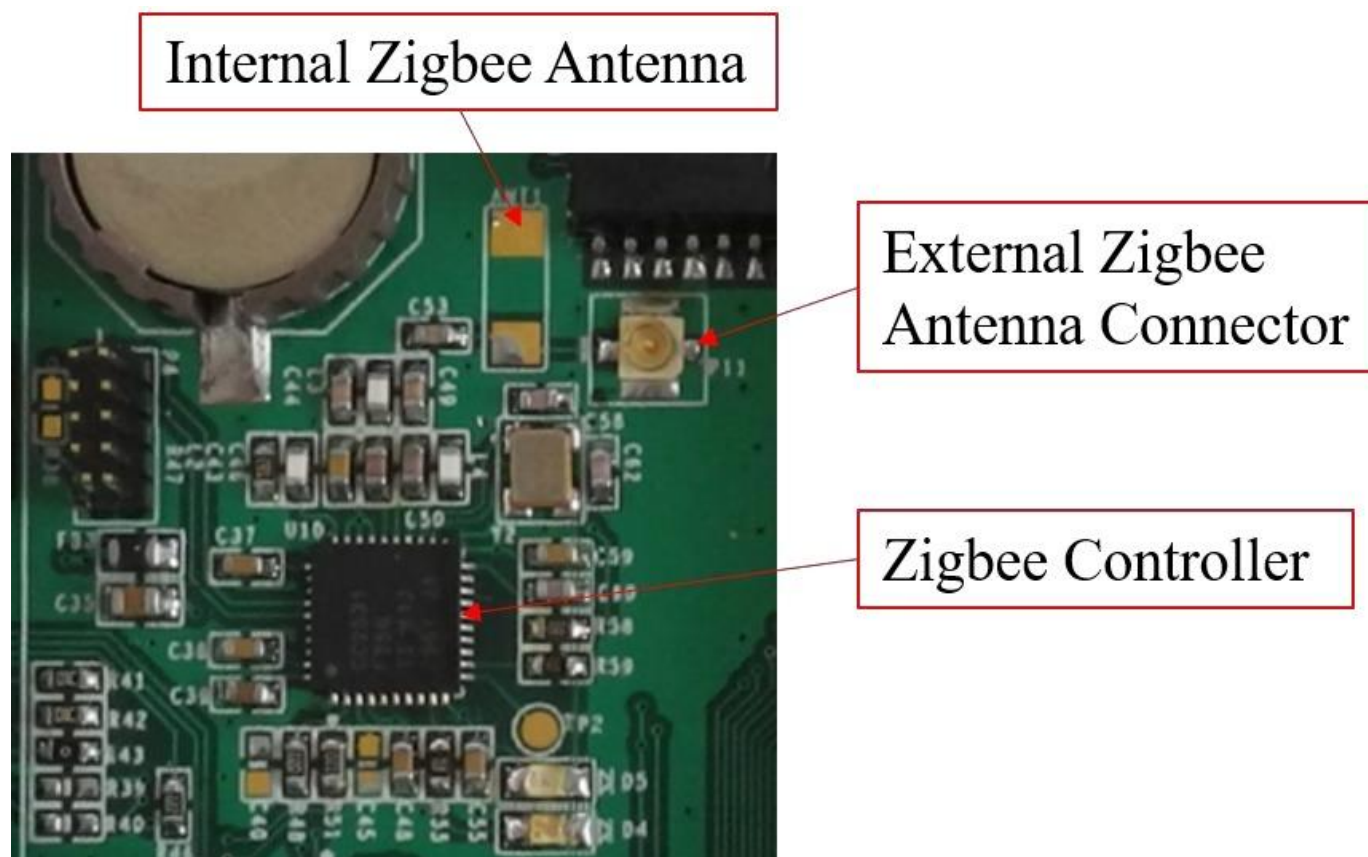
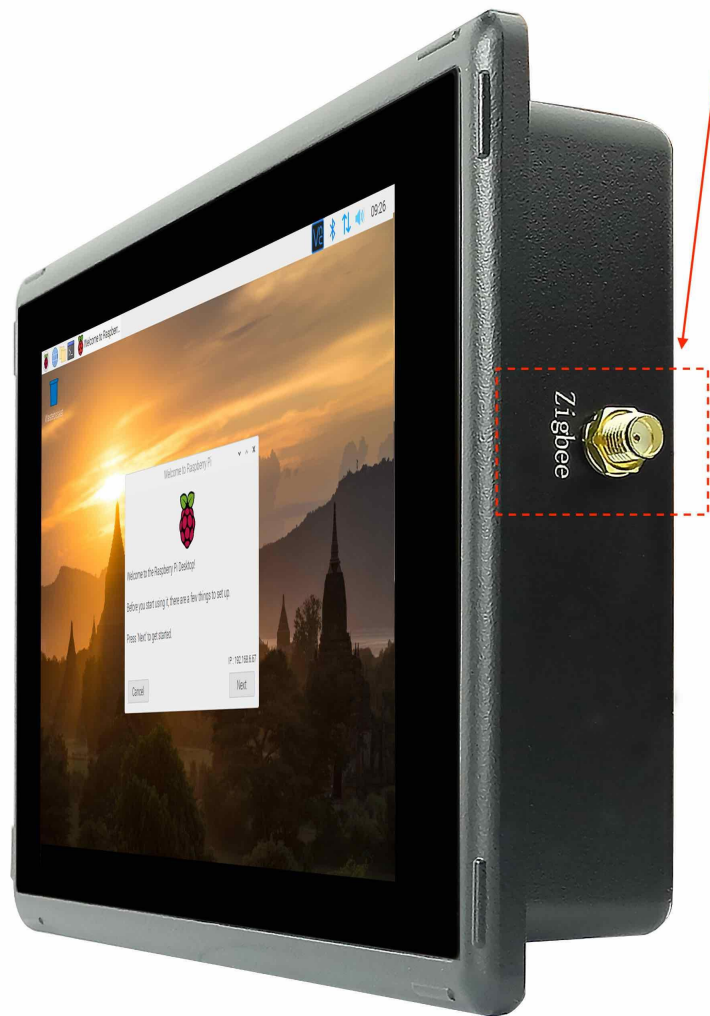

Figure 938: Zigbee controller



Zigbee Antenna

Attention

The product does not come with the Zigbee module by default.

Camera Connector

The PPC-CM4-070-D industrial Pi PC has a 15 Pin **Camera Connector**, as shown in the figure below. The camera signals come from CAM1. The table below gives details about the definition of every Pin.

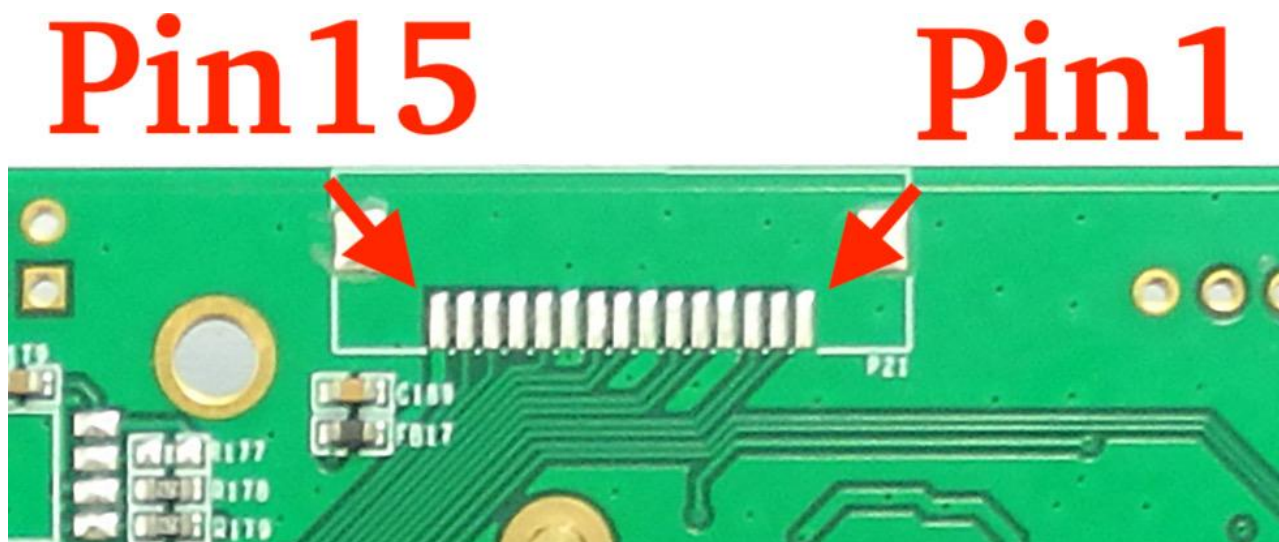

Camera Connector

Camera Connector Pin Definition:		
Pin Number	Definition	Description
Pin 1	GND	Power Ground
Pin 2	CAM1_DN0	CAM1_DN0
Pin 3	CAM1_DP0	CAM1_DP0
Pin 4	GND	Power Ground
Pin 5	CAM1_DN1	CAM1_DN1
Pin 6	CAM1_DP1	CAM1_DP1
Pin 7	GND	Power Ground
Pin 8	CAM1_CN	CAM1 Clock signal Negative
Pin 9	CAM1_CP	CAM1 Clock signal Positive
Pin 10	GND	Power Ground
Pin 11	CAM GPIO	CAM GPIO, use for disable camera power and module
Pin 12	NC	Not connected
Pin 13	SCL0	CPU I2C SCL0 signal
Pin 14	SDA0	CPU I2C SDA0 signal
Pin 15	+3.3V	System +3.3V Power Output, No more than 500mA Current output

Table 295 Camera Connector Pin-out

 **Attention**

1. The camera connector is supported but not mounted by default. It's available on the PCB but not exposed on the case, please contact us when placing an order if you need to use camera on the PPC-CM4-070-D.

TF Card Slot

The PPC-CM4-070-D industrial Pi PC features 1 x **TF Card (micro SD) slot**. A slot can address up to 128GB of memory.

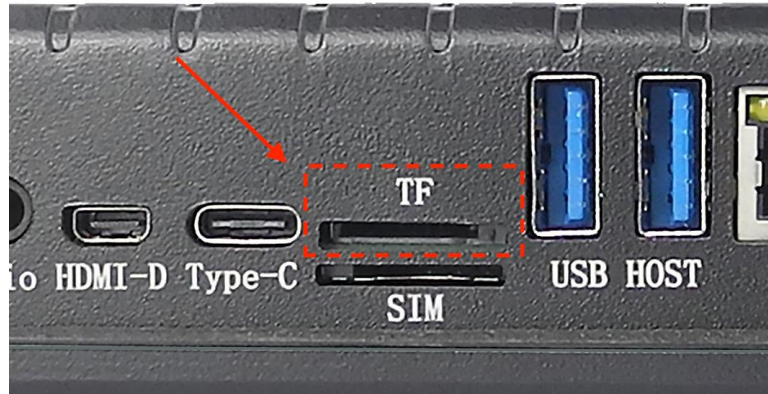

TF (micro SD) Card Slot

Attention

1. The SD is used only for the Lite version of Compute Module 4 that has no internal eMMC, it **can** be used to boot system. If you use CM4 with eMMC, this SD will be disabled.
2. The SD **can't** be used for storage extension.
3. The product does not come shipped with the TF card by default.

Audio Connectors

The PPC-CM4-070-D industrial Pi PC features some audio peripherals. It has 1 x **3.5mm audio output jack**.

Also, the PPC-CM4-070-D industrial Pi PC has a miniature 2W internal speaker for audio reproduction, as well as a small buzzer for alarm/notification sounds.



Audio Connector

Attention

By plugging in the headphone cable, the internal speaker will be disabled automatically.

PROG Button

The PPC-CM4-070-D industrial Pi PC has one button for entering usb download mode, as shown in the figure below.

When booting **with** the button being pressed, the Raspberry Pi will boot from the USB connector. You can use this feature to download the OS software to the internal eMMC. When booting **without pressing** the button, the Raspberry Pi will boot from the internal eMMC.

There is no need to press the button during regular operation. However, if you need to reinstall the OS, please refer to the detailed information on how to reflash the OS from the [Software Documentation](#).

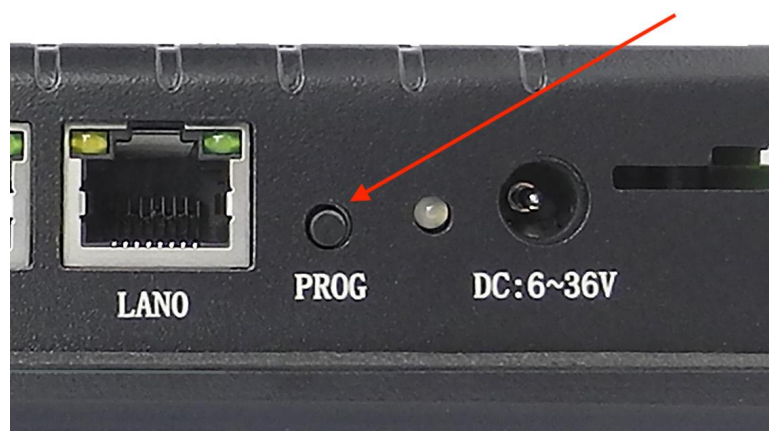

PROG Button

Mounting Procedure

The PPC-CM4-070-D industrial Pi PC can be mounted with 4 x **M4** (6mm) screws using the **VESA** (100x100mm or 75x75mm) mount.

The PPC-CM4-070-D industrial Pi PC can be mounted with **panel mount** method, enabling simplified installation onto any standard mounting fixture.

Attention

Please make sure the display is not exposed to high pressure when mounting into an enclosure.

You can find detailed information about mounting in the [Mount IPC Guide](#).

Mechanical Specifications

CS10600RA4070P-D

For CS10600RA4070P-D, the outer mechanical dimensions are 188.05 x 123.11 x 33.20mm (W x L x H).

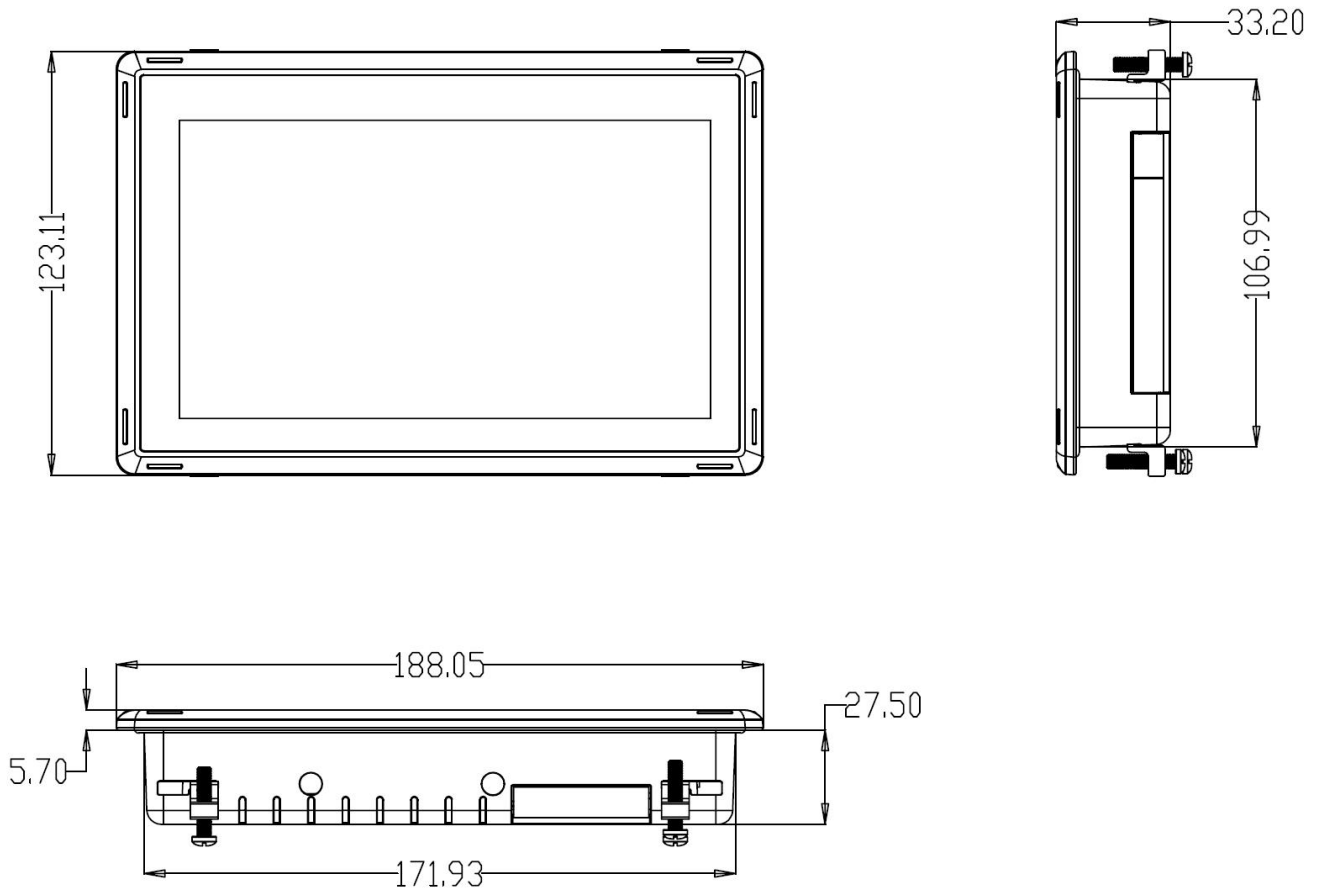

Figure 939: CS10600RA4070P-D Technical Drawing

3D Model

As of Mar 23, 2024, the 3D asset of the product is being actively prepared, and will be available soon.

PPC-CM4-070-D 3D model can be viewed in the online doc in a web browser, **if you are reading from the PDF** version, please visit the online doc [PPC-CM4-070-D](#), select hardware documentation, drag the navigation bar to the 3D Model section.

Disclaimer

This document is provided strictly for informational purposes. Its contents are subject to change without notice. Chipsee assumes no responsibility for any errors that may occur in this document. Furthermore, Chipsee reserves the right to alter the hardware, software, and/or specifications set forth herein at any time without prior notice and undertakes no obligation to update the information contained in this document.

While every effort has been made to ensure the accuracy of the information contained herein, this document is not guaranteed to be error-free. Further, it does not offer any warranties or conditions, whether expressed orally or implied in law, including implied warranties and conditions of merchantability or fitness for a particular purpose. We specifically disclaim any liability with respect to this document, and no contractual obligations are formed either directly or indirectly by this document.

Despite our best efforts to maintain the accuracy of the information in this document, we assume no responsibility for errors or omissions, nor for damages resulting from the use of the information herein. Please note that Chipsee products are not authorized for use as critical components in life support devices or systems.

Technical Support

If you encounter any difficulties or have questions related to this document, we encourage you to refer to our other documentation for potential solutions. If you cannot find the solution you're looking for, feel free to contact us. Please email Chipsee Technical Support at support@chipsee.com, providing all relevant information. We value your queries and suggestions and are committed to providing you with the assistance you require.